

INSTALLATION INSTRUCTIONS

DESCRIPTION: Rock Slider Kit
PART NUMBER: B8K-F11D0-V0
MODEL: '19~ Wolverine X2



⚠ WARNING

Please read and understand these instructions completely before installation to avoid possible injury, or damage to the accessory or vehicle.

NOTICE:

Installation of this kit requires a torque wrench and should be performed by an authorized Yamaha dealer or a qualified mechanic.

WARRANTY INFORMATION:

In the United States, see your Yamaha dealer for a copy of the Yamaha Genuine Accessories Limited Warranty Statement.

DEALER OR INSTALLER:

These instructions contain important information for future reference and *must* be given to the customer.

PARTS LIST:

No.	Part Number	Description	Qty
--	B8K-F11D0-V0	Rock Slider Kit	--
①	*	Rock Slider, Left	1
②	*	Rock Slider, Right	1
③	*	M10x25 Hex Head Flange Bolt	4
④	*	Nut Plate	2
⑤	*	Blind Plug	2
⑥		M8x25mm Hex Head Flange Bolt	4
⑦		M8x25mm Hex Socket Bolt	2

* Part supplied with kit only and not available separately.

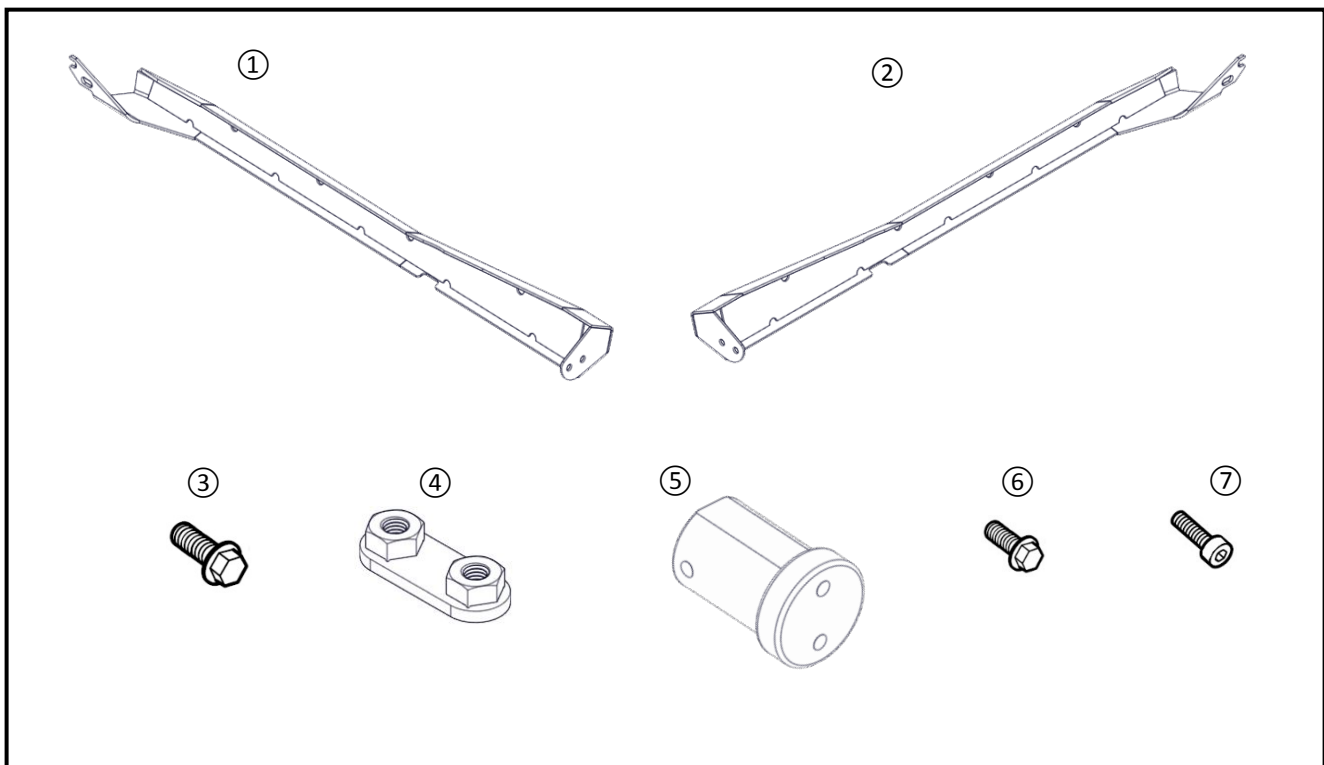

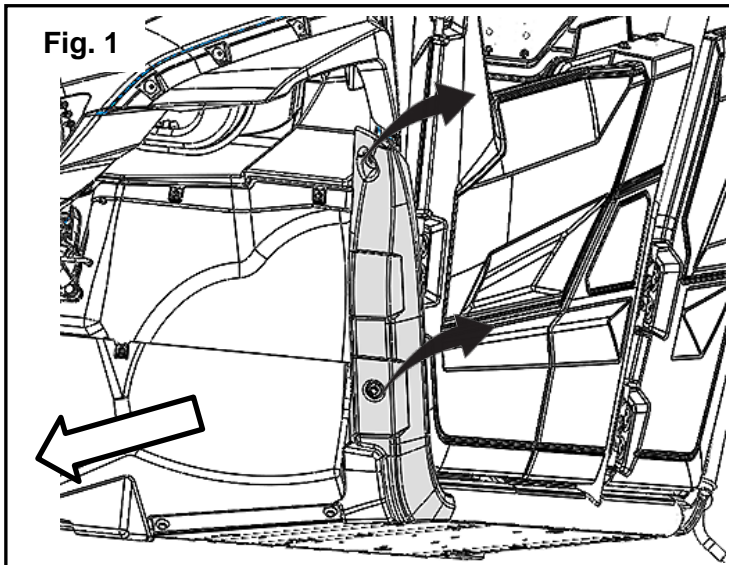

PREPARATION:

- Place the vehicle on a secure and level surface. Set the parking brake.
- Clean the mount surfaces before beginning installation.

INSTALLATION:

1. Starting on the left side, remove front pillar guard and retain all hardware for reuse. There are 2 bolts. See Fig. 1
2. Remove front mudguards, there are 4 bolts and 2 plastic rivets. Retain hardware for reuse. See Fig. 2.
3. Remove the stock plastic plug from the rear of the lower frame tube. See Fig. 3.

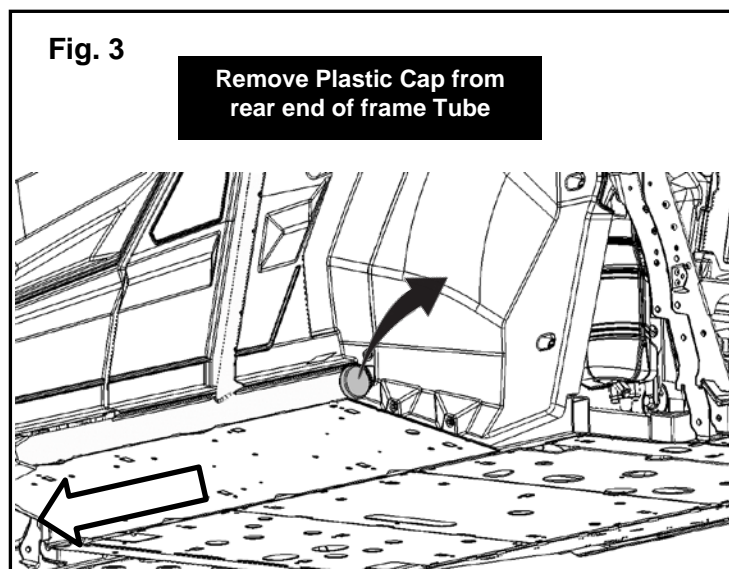
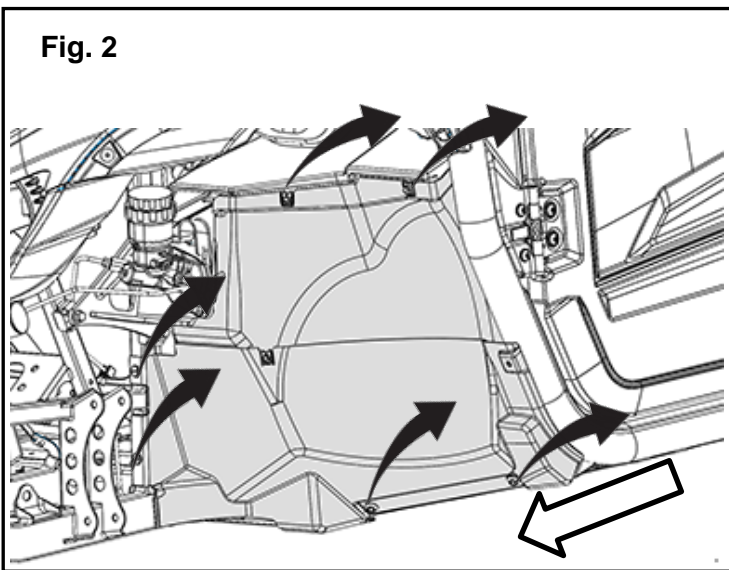

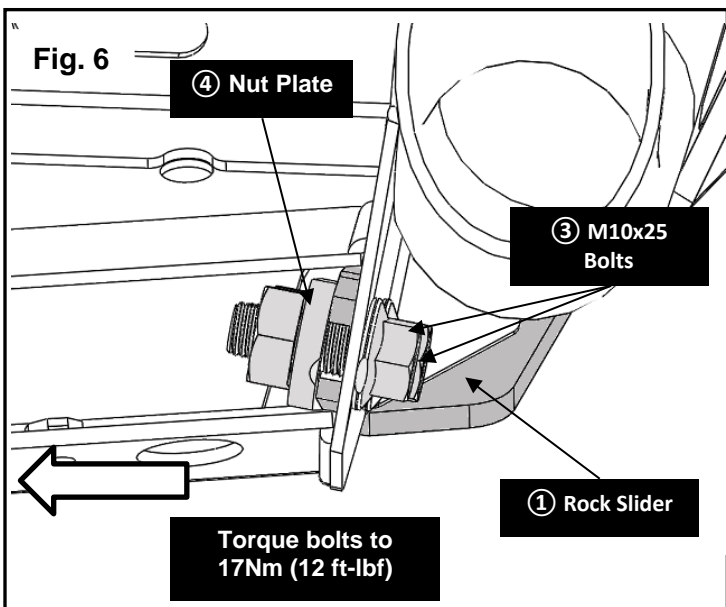
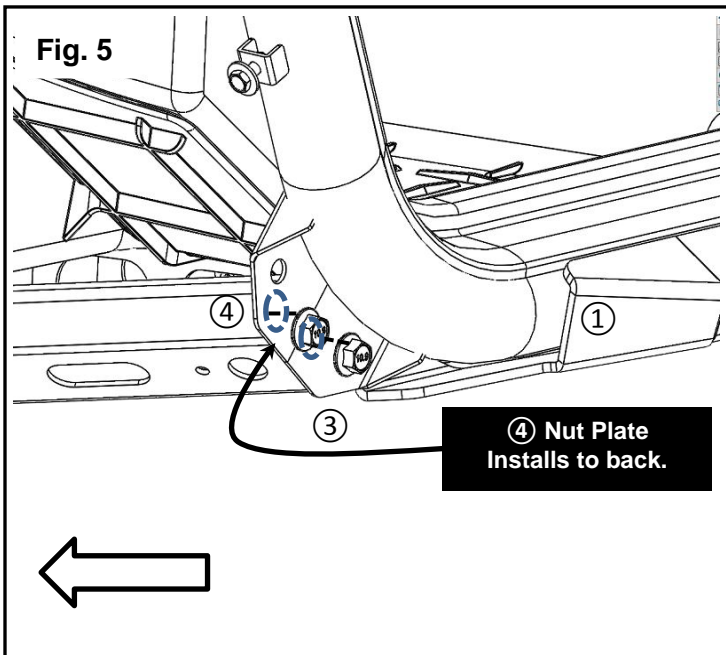
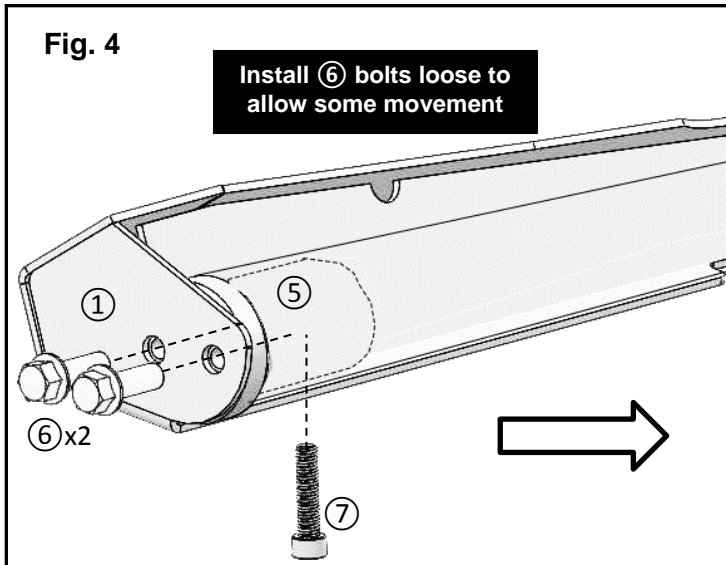

4. Install the Plugs into the opening that had been covered by the plastic plug. Thread in a ⑦ M8x25mm Hex Socket Bolt from below through the frame and into the threads in the ⑤ Plug. See Fig. 4. Torque the bolt to 25 Nm (19 lb-ft).
5. Just in front of the rear wheel, hold the ① Rock Slider, Left up to the rocker tube and thread 2 ⑥ M8x25mm Bolts through the ① Rock Slider and into the ⑤ Plug as shown in Fig. 4. Leave the bolts loose.
6. Just behind the front wheel, hold the ④ Nut plate against the tab in back and the ① Rock Slider in front. Place and pass 2 ③ M10x25mm Bolts through the bolt holes in the frame tab and thread them into the weld nuts on the ④ Weld Nut Plate as shown in Fig. 5 and Fig. 6.
7. Torque the 2 M10x25mm bolts to 50 Nm (37 ft-lbf) and the 2 M8x25mm bolts to 25Nm (19 lb-ft).
8. Repeat steps 1 through 7 on the right side.
9. Install the Front Mudguards and Front Pillar Guards removed in steps 1-3. Refer to the Service Manual for torque settings on these parts.

MAINTENANCE:

Periodically, check torque on all hardware. If loose hardware is found, re-torque to specification.

CARE AND CLEANING:

Clean painted metal parts with a clean soft cloth and mild soap and water solution. Rinse and dry.

CUSTOMER SERVICE:

For further information see your Yamaha dealer.

ESTIMATED TIME TO INSTALL: 1.0 HRS.